

C A M B R I D G E

MODEL 680-P2 PORTABLE SCALE SERIES

Standard Features:

- Carbon steel construction with powder coat finish.
- Two 12", folding, easy incline, side loading ramps.
- (4) Internally mounted, IP 67 water resistant rated load cells.
- Column mounted polycarbonate NEMA 4X junction box for convenient corner adjustments.
 - Structural tubular construction.
 - Diamond tread deck plate with eye bolt holes.
 - 150% Overload protection
 - 100% End loading capacity.
- Shielded load cell cables and 10 foot indicator cable.
 - Ultra-lo profile (1.5" above the floor).
 - 1 part in 5000 accuracy.
- (2) poly bonded 4" straight wheel casters with roller bearings and grease fittings (front).
- (2) poly bonded 4" swivel wheel casters with roller bearings and grease fittings (rear).
 - Wheel jacks to lift and lower scale.
- 40" high indicator column with mounting plate.
 - OSHA orange safety handle grips.

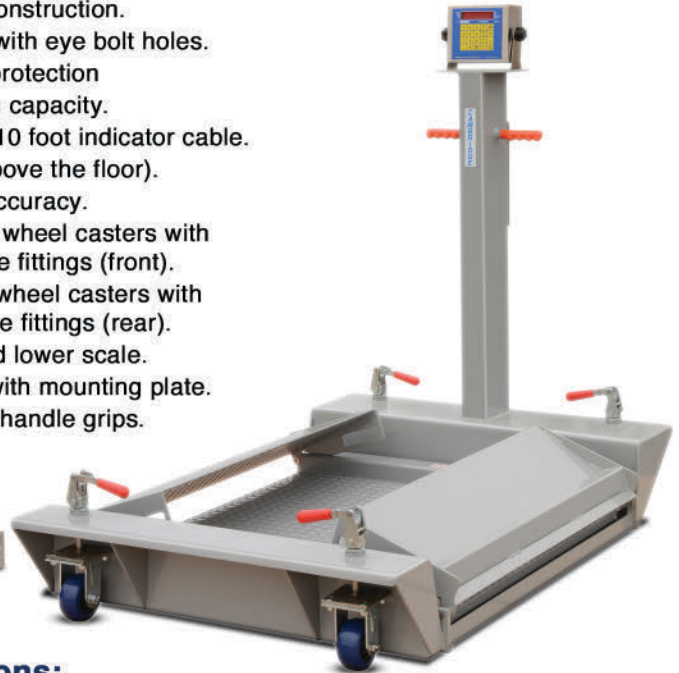

Scales shown with optional indicator.

Applications:

- Pharmaceutical • In-processing weighing
- Mixing vessels • Check weighing
- Laundry carts

Designed for easy use: Lift, Lock, Transport.



Wheel casters and 4" poly bonded wheels with roller bearings and grease fittings lock firmly in the up or down position. This allows the 680-P2 to be easily maneuvered to any location needed and ensures a solid, stable platform when weighing.

Approvals:



Members:

- THE NATIONAL CONFERENCE ON WEIGHTS AND MEASURES
- THE INTERNATIONAL SOCIETY OF WEIGHING AND MEASUREMENT

C A M B R I D G E

MODEL 680-P2 PORTABLE SCALE SERIES

PLATFORM SIZE	CAPACITY & GRADUATION	APPROX. SHIP WEIGHT
30" X 30" X 1.5"	1,000 lbs. X .2 lbs.	405 lbs.
30" X 30" X 1.5"	2,500 lbs. X .5 lbs.	405 lbs.
36" X 36" X 1.5"	1,000 lbs. X .2 lbs.	460 lbs.
36" X 36" X 1.5"	2,500 lbs. X .5 lbs.	460 lbs.
48" X 48" X 2"	1,000 lbs. X .2 lbs.	580 lbs.
48" X 48" X 2"	2,500 lbs. X .5 lbs.	580 lbs.

Dimensions subject to change without notice.

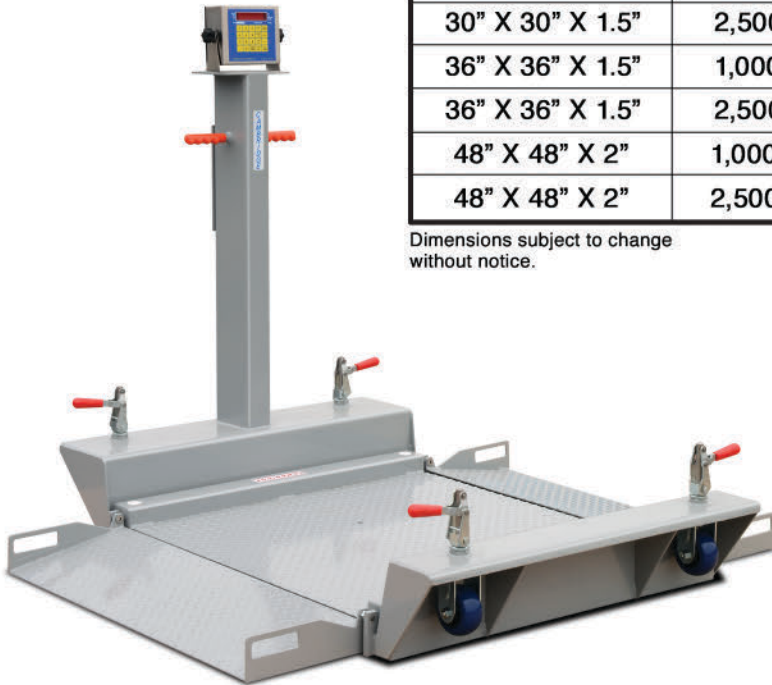

Model 680-P2 Options:

- Smooth deck plate with eye bolt holes.
- Locking rear swivel wheel.
- Indicator mounting plate with 180° swivel.
- Stainless steel load cells.
- Hermetically sealed stainless steel load cells.
- "FM" approved load cells.
- "FM" approved stainless steel Nema 4X junction box.

View of junction box access



The column mounted polycarbonate NEMA 4X junction box allows for quick and easy access. The junction box is mounted to the access panel giving the technician a simple and convenient way to make any necessary corner adjustments.

Distributed By:



- Cambridge Scale Works, Inc. offers a full line of quality, made in America indicators which are designed to perfectly interface with our full line of scales. Be sure to request a genuine Cambridge indicator when ordering your scale.

Cambridge Scale Works, Inc. will warrant this product for one full year against defects in material and/or workmanship.

Cambridge Scale Works, Inc. • P O Box 670 • Honey Brook, PA 19344
(800) 292-7640 • (610) 273-7040 • www.cambridgescale.com

© 2019 Cambridge Scale Works, Inc 12/2019