

C A M B R I D G E

Model LL-FT Coil Series Concentrated Load Scales



Applications:

- Steel Coils
- Aluminum Coils
- Copper Coils
- Cable Spools
- Billets
- Charge Weighing
- Castings
- Steel Scrap

Note: Model LL-FT Coil shown above with optional coil cradle.

Standard Features Include:

- 100,000 Lb capacities
- Cross strutted structural tubular steel construction.
- 1/2 Inch thick smooth carbon steel deck plate.
- Four internally mounted, IP 67 rated water resistant load cells.
- Self checking protective safety yellow framework.
- Polycarbonate NEMA 4x junction box.
- High strength grade 5 hardware.
- Top access to load cells & junction box.
- Durable Urethane Enamel Paint.
- 25 Foot Heavy Duty, High Visibility, Shielded Indicator Cable
- Lag down plates.
- Double link suspension system.
- "Nylatron"[™] Non conductive load cell mounting blocks.

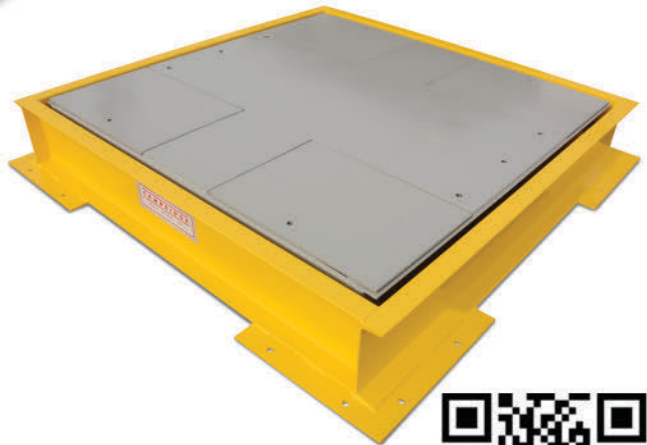

Approvals:



Members:

- THE NATIONAL CONFERENCE ON WEIGHTS AND MEASURES
- THE INTERNATIONAL SOCIETY OF WEIGHING AND MEASUREMENT

C A M B R I D G E

Model LL-FT Coil Series Concentrated Load Scales

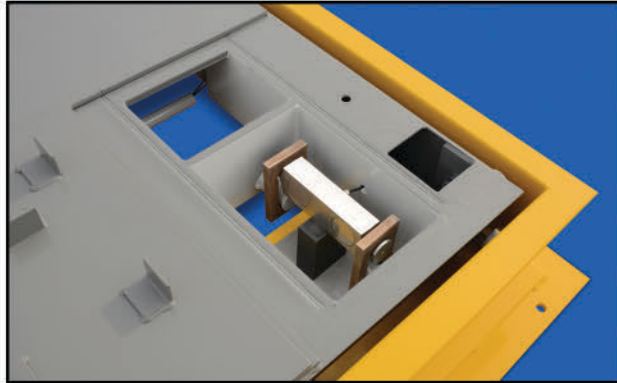

Top access to load cells, polycarbonate NEMA 4x junction box and check stop adjustments.

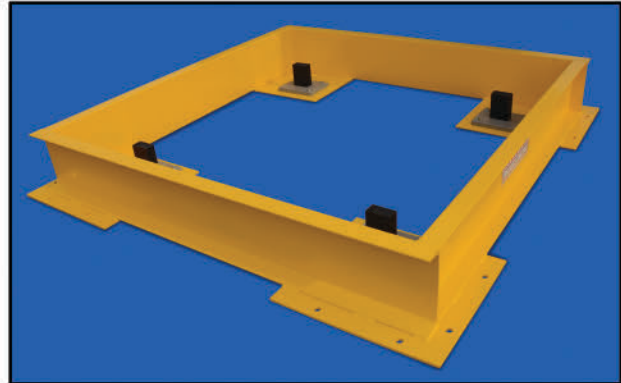

Protective safety yellow framework includes lag down holes and "Nylatron"® Non conductive load cell mounting blocks.

Model LL-FT Specifications (Standard Sizes)

SIZE	CAPACITY	LOAD CELLS QUANTITY & CAPACITY	SHIP WEIGHT
72" x 72" x 12"	100,000 lb.	(4) X 60,000 lb. each	3,895 lb.
72" x 96" x 12"	100,000 lb.	(4) X 60,000 lb. each	5,190 lb.
84" x 96" x 12"	100,000 lb.	(4) X 60,000 lb. each	6,060 lb.
96" x 96" x 12"	100,000 lb.	(4) X 60,000 lb. each	6,925 lb.
120" x 120" x 12"	100,000 lb.	(4) X 60,000 lb. each	10,820 lb.

Specifications subject to change. Custom sizes available, consult factory.

Model LL-FT Options:

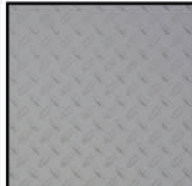

3/8" Diamond deck plate



Stainless steel and/or "FM" approved load cells



SS on-board NEMA 4X junction box

Model LL-FT Accessories:



Coil cradle



48" Indicator column (Freestanding)



Cambridge Scale Works, Inc. will warrant this product for one full year against defects in material and/or workmanship.

Note: Maximum crane speed 12 feet per minute.

Distributed By:

Cambridge Scale Works, Inc. • P O Box 670 • Honey Brook, PA 19344
 (800) 292-7640 • (610) 273-7040 • www.cambridgescale.com

© Cambridge Scale Works, Inc. 3/2016